

Security Systems



PENTAX EUROPE - SECURITY SYSTEMS DIVISION



LINE-SCAN AND AREA-SCAN LENSES

Today's machine vision lenses need to be robust yet compact, high resolution and high contrast but with less vignetting and less distortion.

The lens is the first part of any optical system and as any system is only as strong as the weakest link, it is imperative to start with the best lens possible.

Pentax's Line-scan series were specially designed to provide the optimal image with the following features:

Ultra high resolution and highest contrast

- for 5M sensors and line sensors with 7,450 pixels (4,7 μm)
- optimal image quality for close up applications

Least distortion

- - 0.05% up to + 0.01% on a distance of 45mm

Higher light transmission

- up to 40% increase in light
- even illuminated images from the centre to the outmost edges

High quality manufacture

- Metal housing for highest durability
- Fixing screws for focus and iris
- Click-Stop iris adjustment

Compact size

- Scaling down the size without reducing the transmittance
- \varnothing 60mm



PENTAX

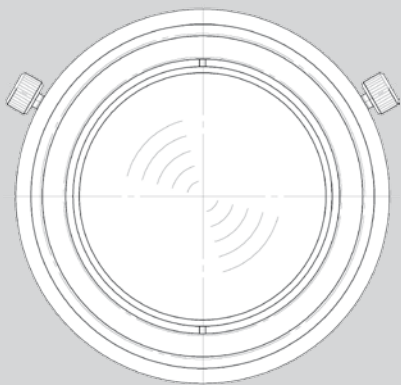

Line-scan and area-scan lenses for line sensors up to 45mm

C52981K YK5028A-02

Magnification 0,15x - 0,23x

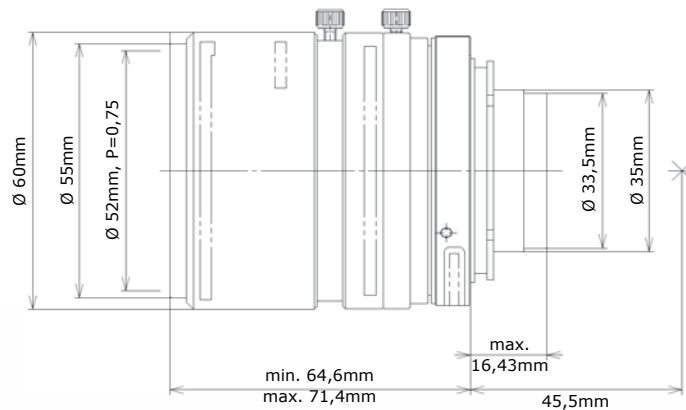

C52980K YK5028A-035

Magnification 0,28x - 0,4x

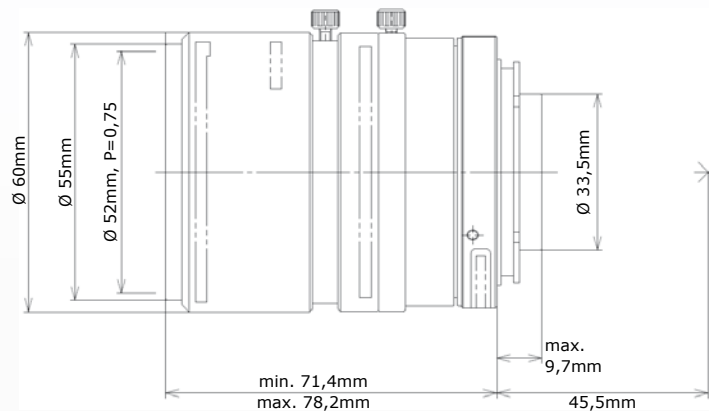

GERMANY, AUSTRIA EUROPE, MIDDLE EAST, AFRICA

PENTAX Europe GmbH
Security Systems Division
Julius-Vosseler-Str. 104
22527 Hamburg
Deutschland
Tel: +49-(0)40-5 61 92-109
Fax: +49-(0)40-5 61 92-334
Email: ssd@pentax.de
Internet: www.pentax.de

UK, IRELAND

PENTAX U. K. Limited
Security Systems Division
Heron Drive
Langley, Slough SL3 8PN
England
Tel: +44-(0)1753-79 27-22
Fax: +44-(0)1753-79 27-94
Email: cctv.sales@pentax.co.uk
Internet: www.pentax.co.uk

FRANCE

PENTAX France S. A. S.
Security Systems Division
112 Quai de Bezons, B.P. 204
95106 Argenteuil Cedex
France
Tel: +33-(0)1-30 25 75 75
Fax: +33-(0)1-30 25 74 47
Email: cctv@pentax.fr
Internet: www.pentax.fr

BELGIUM, NETHERLAND, LUXEMBURG

PENTAX Europe GmbH
Security Systems Division
Julius-Vosseler-Str. 104
22527 Hamburg
Deutschland
Tel: +32-(0)2-3 06 11 97
Fax: +32-(0)2-3 06 12 97
Email: cctv-info@pentaxeurope.com
Internet: www.pentax.nl
www.pentax.be

SWITZERLAND

PENTAX (Schweiz) AG
Security Systems Division
Widenholzstr. 1, Postfach 367
8305 Dietlikon
Schweiz
Tel: +41-(0)44-8 32 82 82
Fax: +41-(0)44-8 32 82 99
Email: cctv@pentax.ch
Internet: www.pentax.ch

Vignetting

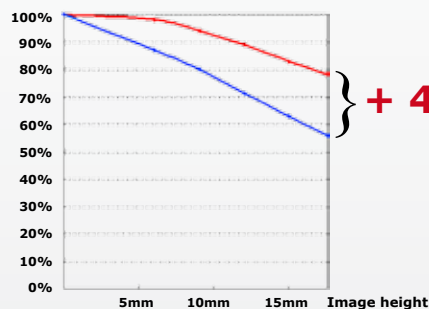

Compared to the previous models, lens vignetting has been improved further.

- Better contrast even from the centre to the outmost edges
- 40% brighter image

Technical specification

Article code	C52981K	C52981F	C52980K	C52980F
Description	YK5028A-02	YF5028A-02	YK5028A-035	YF5028A-035
Sensor length	bis zu 45mm		bis zu 45mm	
Focal length	50mm		50mm	
Max. aperture ration	F1:2,8		F1:2,8	
Standard magnification	0,2x		0,35x	
Min./Max. magnification	0,15x - 0,23x		0,28x - 0,4x	
Working distance	361mm - 242mm		201mm - 146mm	
Filter screw size	M52, P=0,75		M52, P=0,75	
Dimensions	Ø 60mm x 66,4mm		Ø 60mm x 74,2mm	
Mount	K-Mount	F-Mount	K-Mount	F-Mount
	Field of view horizontal / distorsion		Field of view horizontal / distorsion	
2/3" - 5 Megapixel	59mm - 38mm / 0%		31mm - 22mm / 0%	
1,1" - 4 Megapixel	115mm - 74,8mm / 0%		61mm - 43mm / 0,01%	
4.096 Pixel x 7µm	191mm - 125mm / -0,01%		102mm - 72mm / 0,01%	
7.450 Pixel x 4,7µm	234mm - 152mm / -0,03%		125mm - 88mm / 0,01%	
4.096 Pixel x 10µm	273mm - 178mm / -0,05%		146mm - 102mm / 0%	